



Husqvarna DMS 160 AT

DMS 160 AT is a small but powerful electric drill motor and stand system. An ideal choice for light core drilling applications up to 120 mm diameter. For optimal flexibility you can easily angle and rotate the pivot column, saving you time. Suitable for stitch drilling and drilling close to walls and edges in applications such as small channels and pipes as well as electrical sockets.

Motor

Rated input power	1.55 kW
Rated current	6 A
Phases	1 ph
Frequency	50 Hz
Voltage	220-240 V

Dimensions

Drill bit diameter, max	120 mm
Weight	12 kg

Articles for DMS 160 AT

Husqvarna DMS 160 AT

965 15 75-04

Features for DMS 160 AT

Profitable and efficient setup



Several drilling options with one setup.

Overload protection



Increases productivity and extends service life.

Load indicator



The LED indicator shows the load of the machine, allowing the operator to always drill at maximum pressure, for best performance.

Channels, pipes and cables

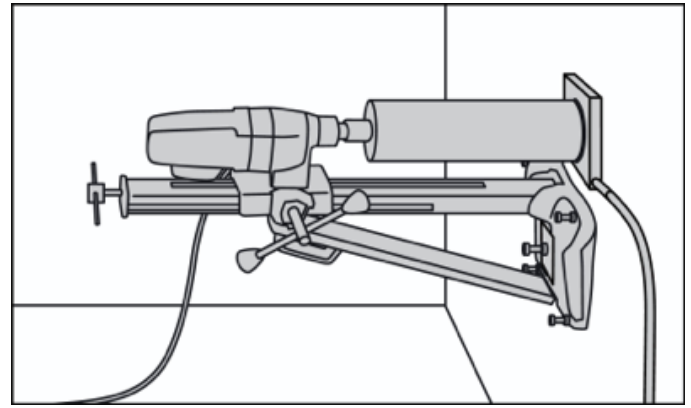

Drilling ventilation channels and holes for pipes and cables.

Recommended tools for DMS 160 AT



D 1235



D 810

Abrasive	● ○ ○	
Asphalt		● ○ ○
Block		● ● ○
Brick	● ● ○	● ● ○
Concrete hard	● ● ●	● ● ●
Concrete medium	● ● ○	● ● ●
Concrete soft	● ○ ○	● ● ●

Cured concrete abrasive		● ● ○
Natural sandstone	● ○ ○	● ● ●
Natural stone	● ● ●	● ● ●
Porcelain	● ○ ○	
Roof tile	● ○ ○	