



## Husqvarna DMS 160 A

DMS 160 A is a small but powerful electric drill motor and stand system. An ideal choice for light core drilling applications up to 120 mm diameter. Suitable for stitch drilling and drilling close to walls and edges in applications such as small channels and pipes as well as electrical sockets.

### Motor

Rated input power	1.55 kW
Rated current	6 A
Phases	1 ph
Frequency	50 Hz
Voltage	220-240 V

### Dimensions

Drill bit diameter, max	120 mm
Weight	10.5 kg

## Articles for DMS 160 A

Husqvarna DMS 160 A

965 15 75-02

## Features for DMS 160 A

### Load indicator



The LED indicator shows the load of the machine, allowing the operator to always drill at maximum pressure, for best performance.

### Overload protection



Increases productivity and extends service life.

### Channels, pipes and cables

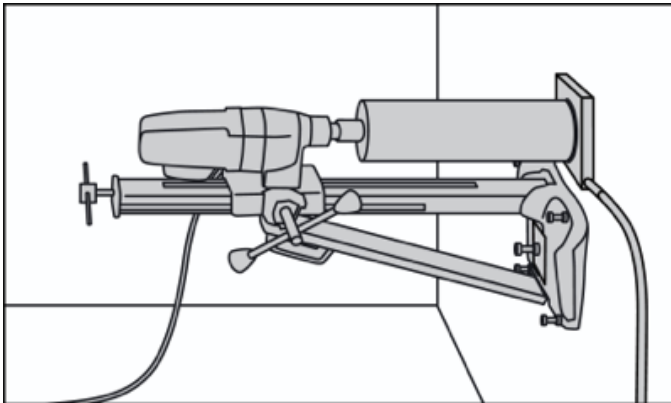

Drilling ventilation channels and holes for pipes and cables.

### Stitch drilling

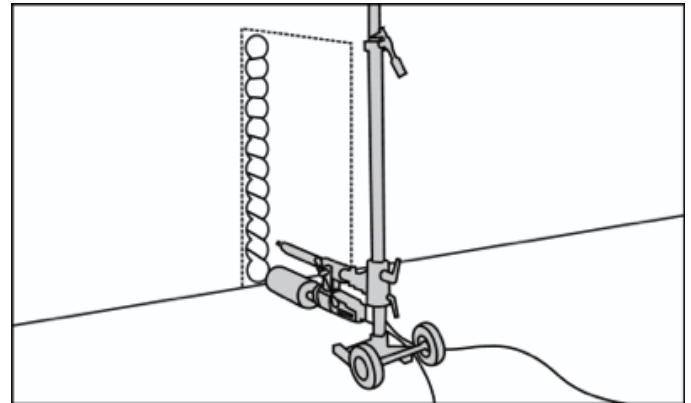

Drilling multiple holes next to each other to make openings.

## Recommended tools for DMS 160 A



D 1235



D 810

Abrasive	● ○ ○	
Asphalt		● ○ ○
Block		● ● ○
Brick	● ● ○	● ● ○
Concrete hard	● ● ●	● ● ●
Concrete medium	● ● ○	● ● ●
Concrete soft	● ○ ○	● ● ●

Cured concrete abrasive		● ● ○
Natural sandstone	● ○ ○	● ● ●
Natural stone	● ● ●	● ● ●
Porcelain	● ○ ○	
Roof tile	● ○ ○	